



DESIGN STATEMENT

The Park Rail is Council's typical post and rail fencing solution for the boundary of reserves. This type of fencing prevents unauthorised vehicles from entering the park whilst providing pedestrian openings at intervals. The Park Rail fencing provides a highly permeable park edge but it is not to be used adjacent to playspaces or dog parks where a more impermeable fencing is needed to prevent children or dogs from running across a road.

APPLICABLE LOCATIONS

Merri-bek open space including conservation areas, parks and reserves.

COUNCIL STANDARD DRAWINGS

B150.05 Park Rail

CROSS REFERENCE DOCUMENT

- B150.04 Park Fence.

STANDARD SPECIFICATIONS

Posts: 150 x 150 x 1500mm white cypress pine bollard with recessed reflector where required. Typically install with in-ground footings as 1200mm high above ground.
Rails: Single 40mm diameter NB hot dipped galvanised steel rail set 900mm from ground level.

SUPPLIER

Varies.

MAINTENANCE

Check fence posts and rails for any damage. Where any fencing is no longer secure in the ground or a rail section has come loose, repair or replace.

GENERAL NOTES

Timber notes: Post

1. Timber for bollard to be durability class 1 Cypress Pine species, dressed all round.
2. All exposed edges on pyramid top to be arrised to min. 5mm.
3. All timber to be free of knots, splinters, cracks or any major defects.
4. Timber finishes – Raw timber is standard. Only where specified otherwise, finish with 3 coats of clear approved timber preservative (satin). Coat entire bollard prior to installing.

Steel Rail

5. 40mm diameter NB hot dipped galvanised rail.

B150.05 Park Rail

Notes:

- Prior to post installation, ensure all timber posts are straight grained, sound and free from spills, warps and splinters.
- Fencing posts to abut pedestrian openings with a clean finish on the rail to ensure no obstruction.
- In general holes not to be drilled completely through timber end posts, if necessary pipe holes to be filled with a wooden plug to fit and pipe to be fixed with adhesive or securely fastened in place with bolts or screws.
- All fixtures to be hot dipped galvanised.

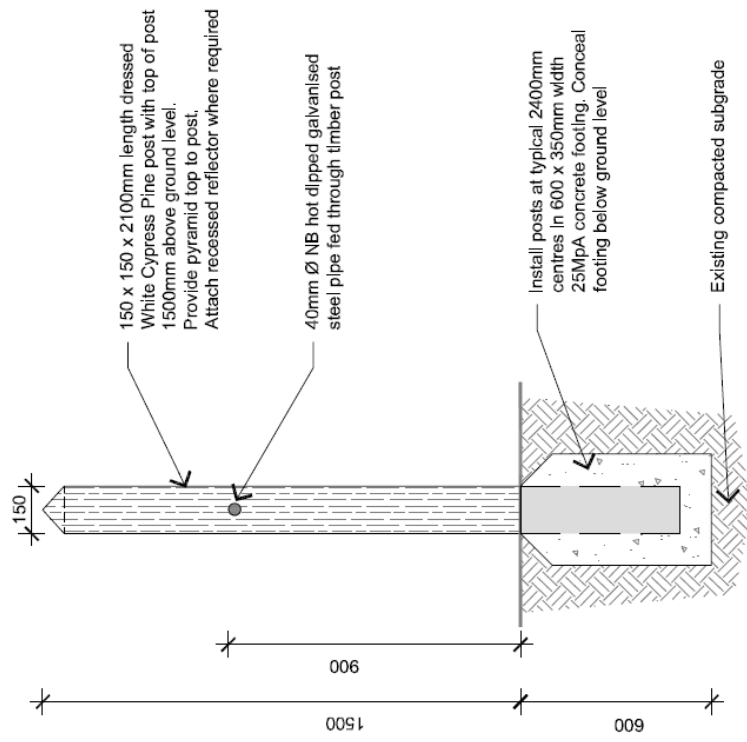

01 PARK POST AND RAIL
Cross Section
1:20

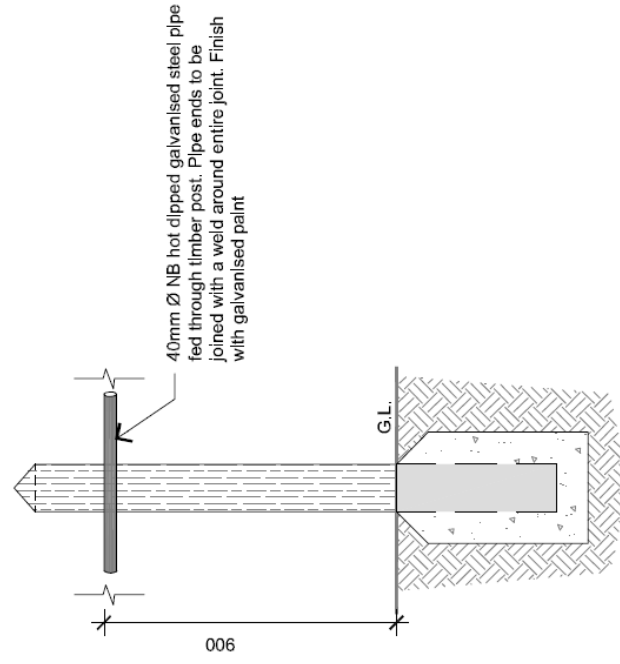

02 PARK POST AND RAIL
Section
1:20

Notes:

- Spacing: Include minimum 1.2m wide pedestrian entry point after every third post.

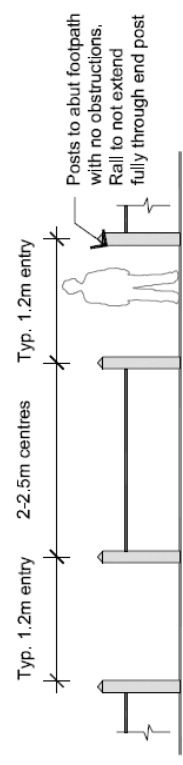

03 PARK POST AND RAIL
Elevation
NTS