



DESIGN STATEMENT

The Park Fence is Council's standard fencing solution for park and playspace boundaries where they abut roadways. The horizontal rail fencing restricts children and most dogs from running out to the road. Typically the Park Fence is installed with secure lift up pedestrian gates ('pool gate' style).

The powdercoated black steel fencing is softened by using timber posts and both the timber posts and steel panels are visually noticeable to motorists, cyclists and pedestrians.

APPLICABLE LOCATIONS

Merri-bek open space including conservation areas, parks, playspaces and reserves.

COUNCIL STANDARD DRAWINGS

B150.04 Park Fence

CROSS REFERENCE DOCUMENT

- B150.05 Park Rail.

STANDARD SPECIFICATIONS

Posts: 150 x 150 x 1500mm white cypress pine bollard with recessed reflector where required. Typically install with in-ground footings as 1200mm high above ground.

Panels: 900mm high tubular hot dipped galvanised steel flat horizontal bars, powdercoated black. Centrally position to each post with two brackets, leaving a 100mm clearance above ground.

SUPPLIER

Varies.

MAINTENANCE

Check fence posts and fence panels for any damage. Where any fencing is no longer secure in the ground, repair or replace.

GENERAL NOTES

Timber notes: Post

1. Timber for bollard to be durability class 1 Cypress Pine species, dressed all round.
2. All exposed edges on pyramid top to be arrised to min. 5mm.
3. All timber to be free of knots, splinters, cracks or any major defects.
4. Timber finishes – Raw timber is standard. Only where specified otherwise, finish with 3 coats of clear approved timber preservative (satin). Coat entire bollard prior to installing.

Steel Panel

5. Ensure no sharp edges on bracket or bars.

B150.04 Park Fence

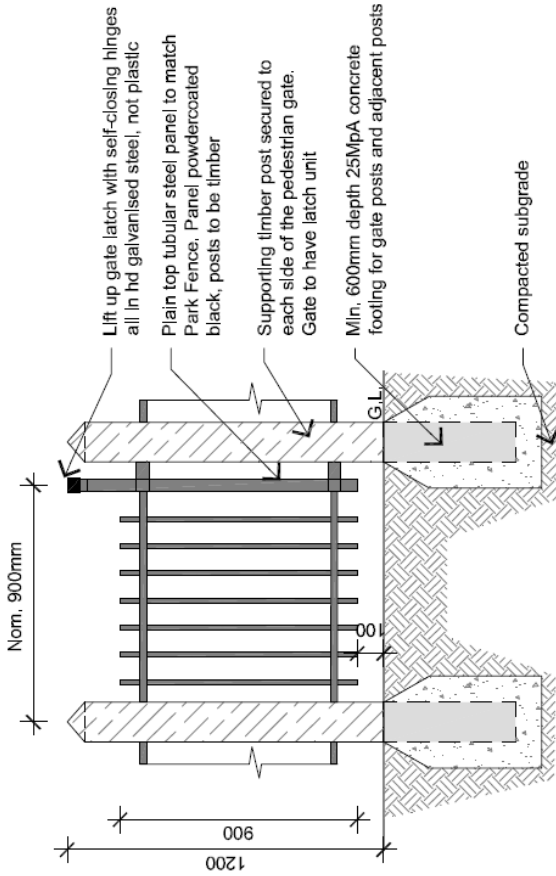

02 PARK FENCE GATE
Front Elevation
1:25

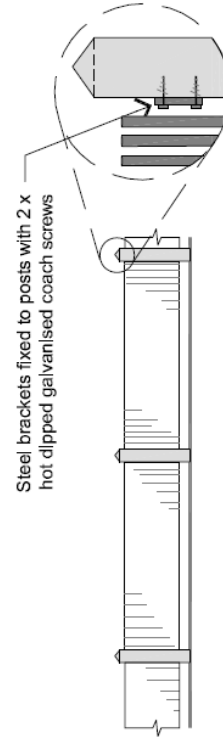

03 PARK FENCE - Steel Panel
Elevation
NTS

- Notes:
- Prior to post installation, ensure all timber posts are straight, grained, sound and free from spills, warps and splinters.
 - All fixtures to be hot dipped galvanised steel. Ensure there are no sharp edges on either posts or panels.
 - Centrally position fencing panel to each post, leaving 100mm gap to ground level.
 - For ease of mowing adjacent to fencing, remove min. 250mm of lawn on both sides of fence and install compacted Tuscan Toppings gravel.

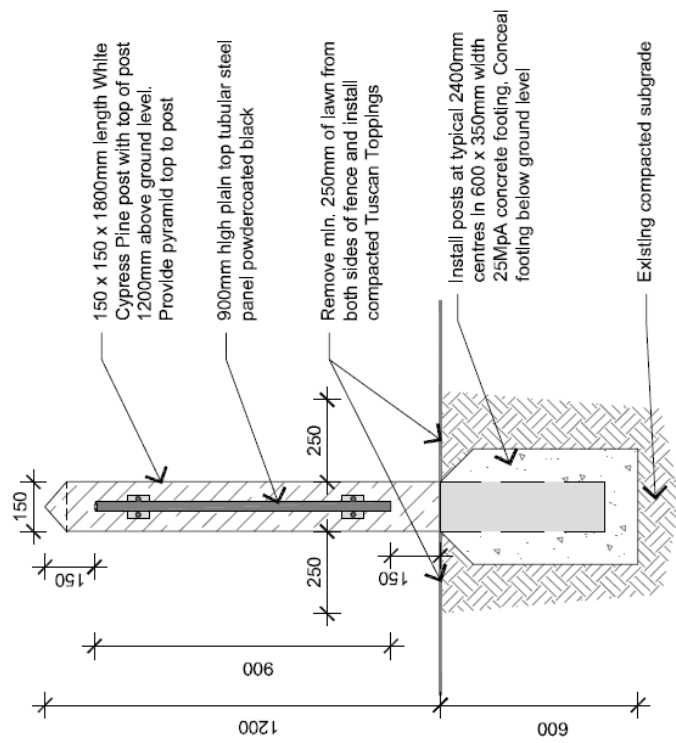

01 PARK FENCE - Steel Panel
Cross Section
1:20