Circular Bench B120.10



DESIGN STATEMENT

Circular bench is used to provide variation of public seat setting which is sturdy yet inviting. Timber/composite timber provides a comfortable seating surface. The seat is placed on top of precast concrete which doubles up as protective impact-furniture.

APPLICABLE LOCATION

Small shopping strips, as specified.

COUNCIL STANDARD DRAWING

N/A

CROSS REFERENCE DOCUMENT

- Merri-bek Small Shopping Strip Public Domain Manual

STANDARD SPECIFICATION

Timber Top: Custom Bonwick Street Circular Wall Bench by CSA. Welded metal sheet with black paint on the metal frame using 2-pack paint protective coating.

Slats Finish:

Option 1 - Recycled composite timber 'Walnut' EnviroSlats, or other similar composite timber.

Option 2 - Hardwood timber slats size 30x40mm.

Pre-cast concrete: SVC Ottoman Seat 1000mm dia x 500mm high. Finish: shot blasted-light white colour.

SUPPLIER

Timber top: Commercial System Australia or similar.

Precast concrete: SVC or similar.

MAINTENANCE

Council Roads Unit: Hardwood located in outdoor areas should be initially re-coated after 3 months, and every 6 months thereafter. Re-coating should be done with coats of timber oil. For degraded surface which appears greying and checking, a light sanding is recommended to freshen up the timber.

Street Cleansing Unit: Remove graffiti when required with graffiti remover for timber slats, or rub with metal scourer for composite timber slats. Paint on metal can be recoated using similar paint after detergent degreasing and light abrasion.

GENERAL NOTES

1. Refer to manufacturer's installation manual

B120.03 Circular Bench

BATTEN: ENVIROSLAT COMPOSITE
PROFILE: 135X30MM
COLOUR: WALNUT
FINISH: WOODGRAIN EMBOSSED
EDGES: 3mm PENCIL ROUND
FIXING: SCREW FIXED FROM BEHIND. 14 GAUGE, STAINLESS STEEL BUTTON HEAD SCREWS

FIXING METHOD
M10 CHEMSET FIXING, TOTAL 4 REQ.
150mm ALL THREAD SPIGOTS SUPPLIED
SECURED WITH COUNTERSUNK TORX
STAINLESS STEEL BARREL NUTS

FRAME MATERIAL: MILD STEEL
FINISH: POWDERCOATED
COLOUR: LUNAR ECLIPSE

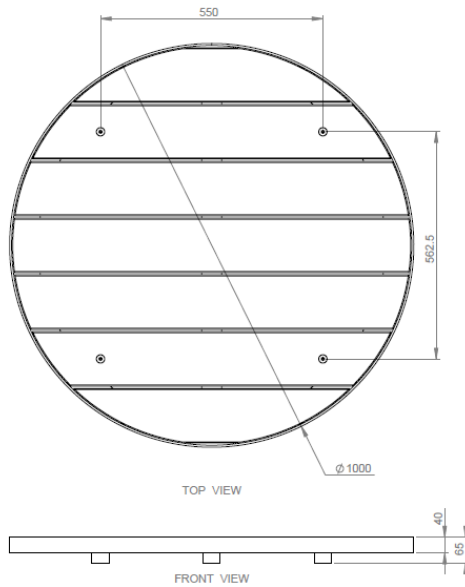
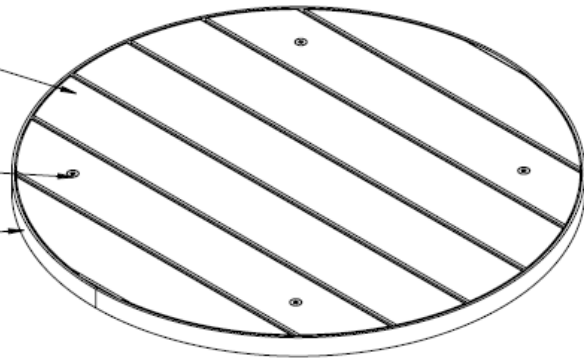

Copyright: CSA



Copyright: SVC