Vehicle Crossing in Asphalt for Sawn Bluestone Kerb and Channel



GENERAL NOTES

1. A Vehicle Crossing Permit is required.
2. Asphalt vehicular crossing is only to be used in street having full width asphalt footpath and sawn bluestone kerb.
3. Splay $S = 1.00m$ for residential, $=1.50m$ for commercial/industrial.
4. All joints to existing asphalt to be sawcut, cleaned and tack-coated.
5. Council's inspection officer to have discretion to vary standard, depending on existing street conditions including crossing shape and the treatment of the street channel.
6. Kerb transition to be 0.5m.
7. Refer to AS 2890.1 to ensure vehicles are not scraping.
8. Refer to Road Pavement Reinstatement in Front of New Vehicle Crossing SD 265E.

DESIGN STATEMENT

Asphalt crossing is an economical alternative vehicular crossing for various established areas within Merri-bek. The bluestone kerb and channel for vehicle crossing is designed to create a smooth and continuous edging and surface drainage, yet provide a traditional material interface between the driveway and the road pavement.

APPLICABLE LOCATION

To be applied to streets as specified in Coburg Streetscape Masterplan and Brunswick Public Realm Design Manual.

COUNCIL STANDARD DRAWING

N/A

CROSS REFERENCE DOCUMENT

- AS1428.1-1998 (Australian Standard for access and mobility)
- AS2890.1-2004 (Australian Standard for Parking Facilities – Off Street Parking)
- Refer to Merri-bek City Council's Standards Specifications: Section 80, Section 60, and Section 82.
- Coburg Streetscape Masterplan
- Brunswick Public Realm Design Manual

STANDARD SPECIFICATION

All vehicle crossings should be graded to finish flush with existing road grades and footpaths to also enable a continuous and safe pedestrian access zone.

Bluestone should be sourced locally whenever possible.

SUPPLIER

N/A

MAINTENANCE

Street Cleansing Unit: Channel of vehicular crossing to be cleaned as per current schedule.

Roads Unit: Channel to be maintained.

Property Owner: The maintenance of vehicle crossings is the responsibility of the property owners.

A170.11 Vehicle Crossing in Asphalt for Sawn Bluestone Kerb and Channel

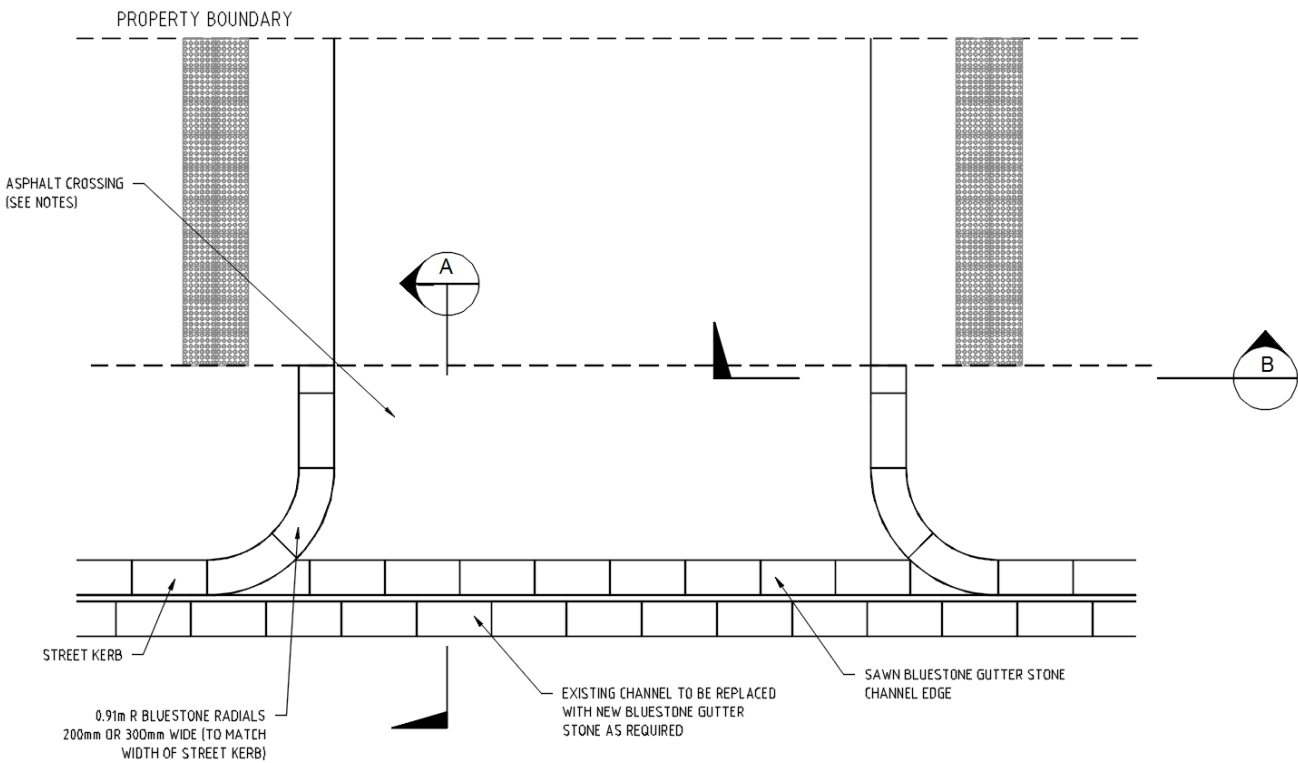

PLAN
NTS

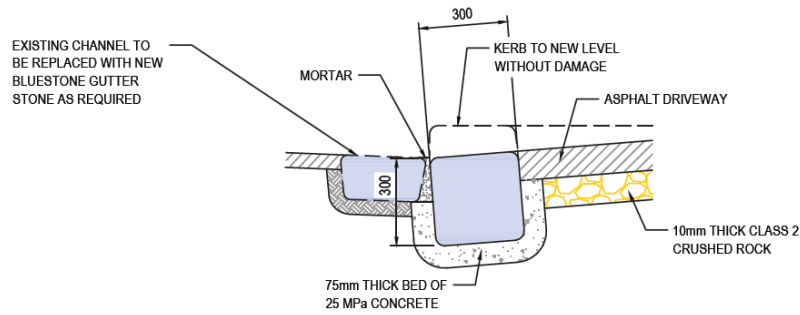

SECTION A
NTS

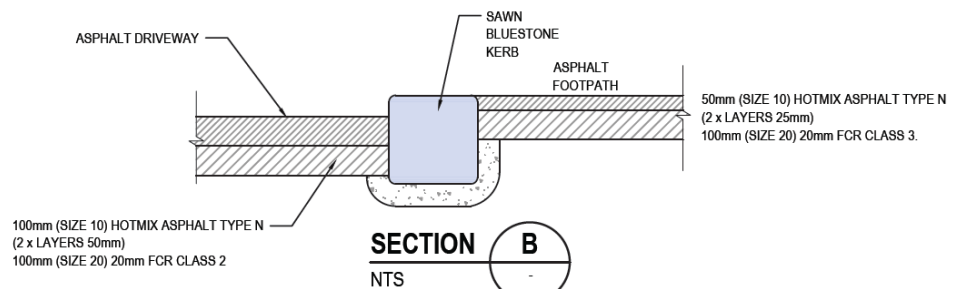

SECTION B
NTS