

# Pedestrian Threshold Crossing with A160.03 Bluestone Pitcher Ramp



Flat top: Grey concrete



Flat top: Sawn bluestone pitcher

## DESIGN STATEMENT

Pedestrian threshold crossing with concrete top provides better accessibility and safety for pedestrians to cross. The crossing prioritises pedestrian movement and improves the civic feel of the area.

Smooth bluestone or grey concrete flat top allows easy access for wheelchair and prams. The inclusion of rough cut pitchers within the slope of the crossing encourages vehicle drivers to slow down at these intersections.

## APPLICABLE LOCATION

To be applied to shared zone entry points and future threshold crossing locations within the Coburg, Brunswick and Glenroy Activity Centre.

## CROSS REFERENCE DOCUMENT

- AS1428.1-2009 (Australian Specification and Standard design for access and mobility)
- If tactile warning is applied, refer to AS/NZS1428.4.1(2009)
- AS1379 (Australian Specification and Standard Supply of Concrete)
- AS4671 – Reinforcement Standard
- AS 3600-2001 – Concrete Standard
- Coburg Streetscape Masterplan
- Merri-bek City Council's Standards Specifications: Section 80, Section 60, and Section 82

## STANDARD SPECIFICATION

**Flat top:** Sawn bluestone pitcher or grey-coloured concrete.

All vehicle crossing (and paver support base) should be graded to finish flush with existing road grades and footpaths to enable a continuous and safe pedestrian surface.

**Ramp:** Rough bluestone pitchers, preferably recycled.

**Concrete strength for paver support base:** Concrete strength is to be 25 MPA (28 day compressive strength).

Bluestone should be sourced locally whenever possible, and preferably recycled.

## GENERAL NOTES

1. Concrete base thickness shall be 150 mm minimum depth, using reinforcement to AS4671, with SL82 mesh placed centrally. For all other uses the base thickness and reinforcement shall be designed to take into account the type of vehicle using the crossing.
2. Asphalt ramps to be neatly chased into existing pavement. Chases to be minimum 300mm wide and 30mm deep.
3. TGS1 to be installed as per AS/NZS1428.4.1(2009).

## SUPPLIER

N/A

## MAINTENANCE:

**Street Cleansing Unit:** Cleaning will be undertaken as per current schedule.

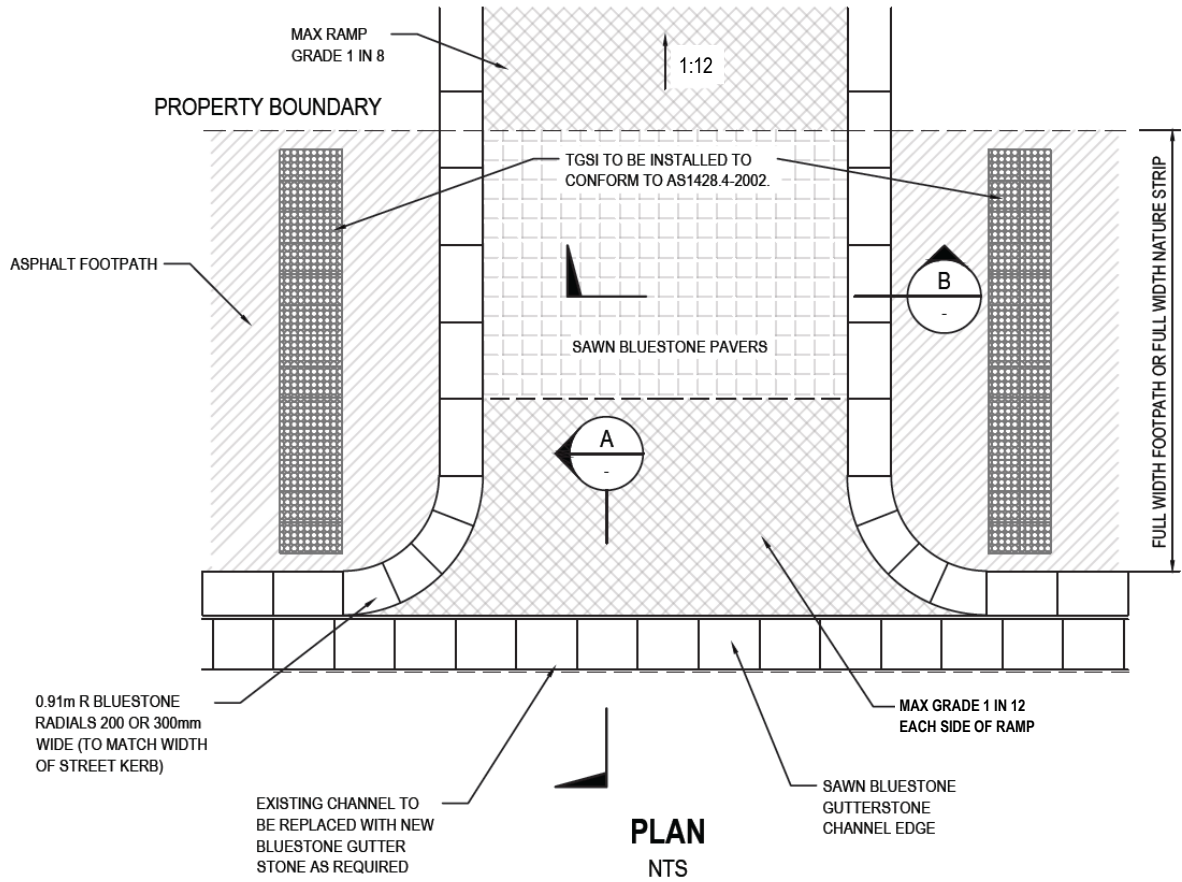

# A160.03 Pedestrian Threshold Crossing with Bluestone Pitcher Ramp



### PAVEMENT MARKING REQUIREMENTS AT RAMPS

SPECIFIED RAMP SLOPE	PIANO KEY MARKINGS & RRPM'S
1 in 12	Required
1 in 20	Not Required

### LEGEND:

-  ASPHALT PATH AREA
-  ROUGH CUT BLUESTONE ROAD PAVEMENT (MAX GRADE 1 IN 8)
-  SAWN BLUESTONE PAVERS

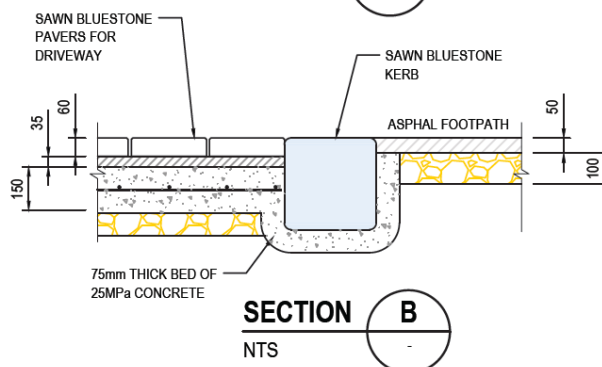
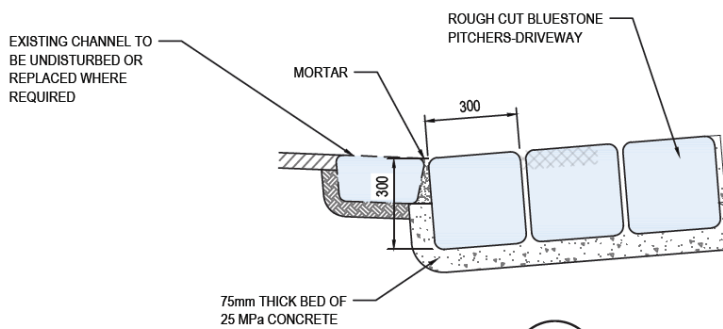

O