

---

# Property Drain Connection Details A140.16

---



GENERAL

## DESIGN STATEMENT

Property drain connection details are how the stormwater drains collecting rainwater run-off on private property, connect (in the road reserve) to Council's drainage pipe or kerb and channel (whichever has been specified in the Legal Point of Discharge Report obtained from Council). A Drainage Connection Permit and a Road Opening Permit must be obtained from Council for permission to make the connection to the drain and make an opening in the road reserve, respectively.

## APPLICABLE LOCATION

House drain connection details must be adhered to when connecting private property house drains to Council's drainage system in the road reserve.

## COUNCIL STANDARD DRAWING

SD 150 House drain connection details.

## CROSS REFERENCE DOCUMENT

- Merri-bek City Council Standard Specification Section 60.

## STANDARD SPECIFICATION

Refer to Notes 1-6 for the standard specifications.

## SUPPLIER

N/A

## MAINTENANCE

**Property Owner:** Maintenance of private property house drains and connection, up to Council main drain, is the responsibility of the property owner. This includes the portion within the road reserve.

## GENERAL NOTES

1. House drain pipe to be Vinidex DVW sewer pipe SCJ, 100mm diameter UPVC, Class SN6, with solvent weld joint or equivalent.
2. Saddle adaptor to be Flowcon PVC Conconnect or approved equivalent.
3. Kerb adaptor to be C&E Enterprises (Ph 1800 646 018) type C1 or approved equivalent fitted in accordance with manufacturer specifications.
4. All inspection openings located in paved areas to be fitted with 150x150 Fitzroy boxes from 'Australian Road Covers' or approved equivalent.
5. 'IO' or 'O' are to be stamped on kerb and channel opposite inspection openings to house the drain connection.
6. The reinstatement of existing house drain for road reconstruction to be up to the property boundary line with a suitable adapter to connect new drain pipe to existing drain pipe.

# A140.16 Property Drain Connection Details

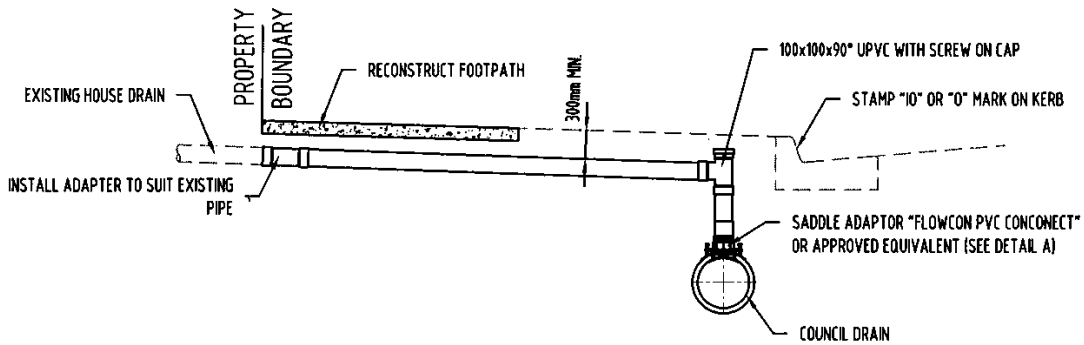

CONNECTION TO DRAIN LOCATED IN NATURE STRIP

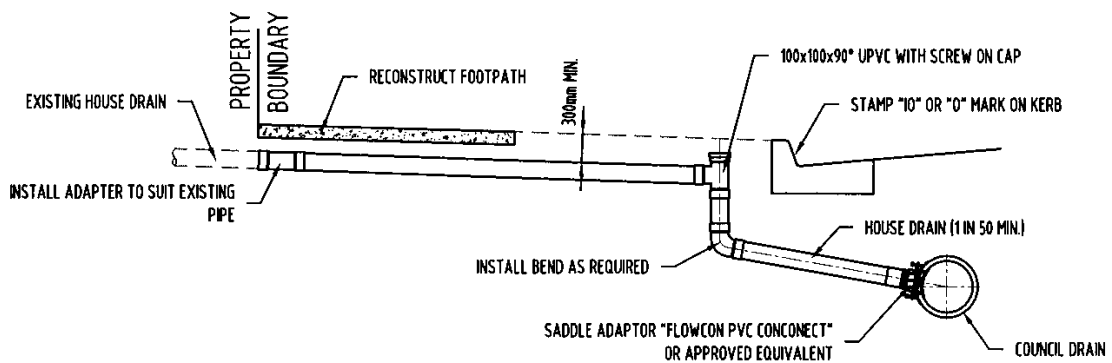

CONNECTION TO DRAIN LOCATED UNDER KERB&CHANNEL / IN PAVEMENT

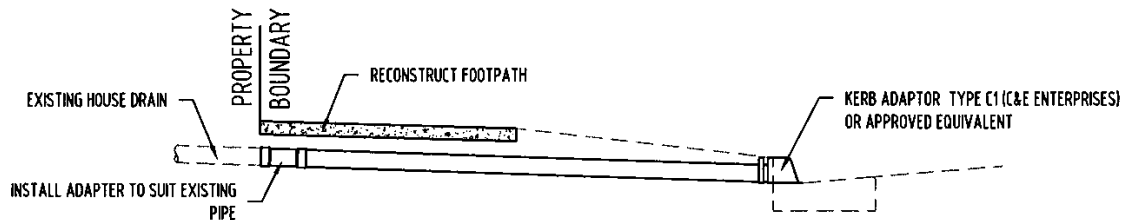

CONNECTION TO KERB&CHANNEL

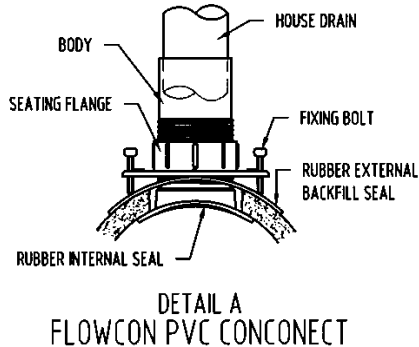

## NOTES:

1. HOUSE DRAIN PIPE TO BE VINIDEX DWV SEWER PIPE SCJ, 100MMØ, CLASS SN6, WITH SOLVENT WELD JOINT OR EQUIVALENT.
2. SADDLE ADAPTOR TO BE FLOWCON PVC CONCONNECT OR APPROVED EQUIVALENT.
3. KERB ADAPTOR TO BE C&E ENTERPRISES (PH. 1800 646 018) TYPE C1 OR APPROVED EQUIVALENT FITTED IN ACCORDANCE WITH MANUFACTURER SPECIFICATION.
4. ALL INSPECTION OPENINGS LOCATED IN PAVED AREAS TO BE FITTED WITH 150X150MM FITZROY BOXES FROM " AUSTRALIAN ROAD COVERS" OR APPROVED EQUIVALENT.
5. "10" OR "0" MARKS ARE TO BE STAMPED ON KERB & CHANNEL OPPOSITE INSPECTION OPENINGS TO HOUSE DRAIN CONNECTIONS.
6. THE REINSTATEMENT OF EXISTING HOUSE DRAIN FOR ROAD RECONSTRUCTION TO BE UP TO THE PROPERTY BOUNDARY LINE WITH A SUITABLE ADAPTER TO CONNECT NEW DRAIN PIPE TO EXISTING DRAIN PIPE.