



## DESIGN STATEMENT

The grated pit is a standard open grate pit located within ROW or paving areas. The grate is selected depending on traffic conditions.

## APPLICABLE LOCATION

The grating pit should be used where advised by City Infrastructure Department of Merri-bek City Council.

## COUNCIL STANDARD DRAWING

SD 126 Grated pit (900x900).

## CROSS REFERENCE DOCUMENT

- Merri-bek City Council Standard Specifications: Sections 80 & 60. See Also: Urban Stormwater: Best Practice Environmental Management Guidelines; CSIRO Publishing.

## STANDARD SPECIFICATION

**Concrete strength:** 25 MPa, unless stated otherwise.

**Pits:** Shall be cast monolithically. Cement render shall only be used to repair defects. Pits over 2m in depth shall have F72 reinforcing fabric placed centrally in walls.

Step irons shall be fitted to pits greater than 1m in depth (See SD 190). Minimum internal dimensions to be 900x900.

Refer to Notes 1-3 as detailed in general note.

## SUPPLIER

### Supplier of grates:

- Access Covers P/L
- R&S Grating P/L
- SVC Products P/L
- Terra Firma Industries P/L
- Weldlok Grates P/L
- Gatic P/L or approved similar

## MAINTENANCE

**Street Cleansing Unit:** Cleaning will be undertaken as per current schedule.

## GENERAL NOTES

1. For bluestone paver or asphalt right of ways, any exposed concrete shall be charcoal coloured.
2. Grate to be :
  - Access Covers P/L
  - R&S Grating P/L
  - SVC Products P/L
  - Terra Firma Industries P/L
  - Weldlok Grates P/L
  - Gatic P/L or approved similar
3. Similar grate and frame shall galvanise steel with the grate hinged to its frame and bolt down. The proposed grate and frame set must be approved by Council prior to being used and to be bicycle safe.

# A140.08 Grated Pit

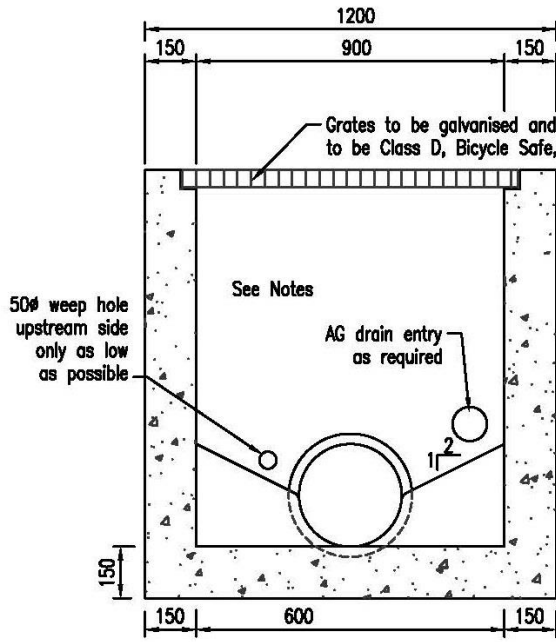

FOR PIPES UP TO 750mm  $\phi$   
SECTION A-A

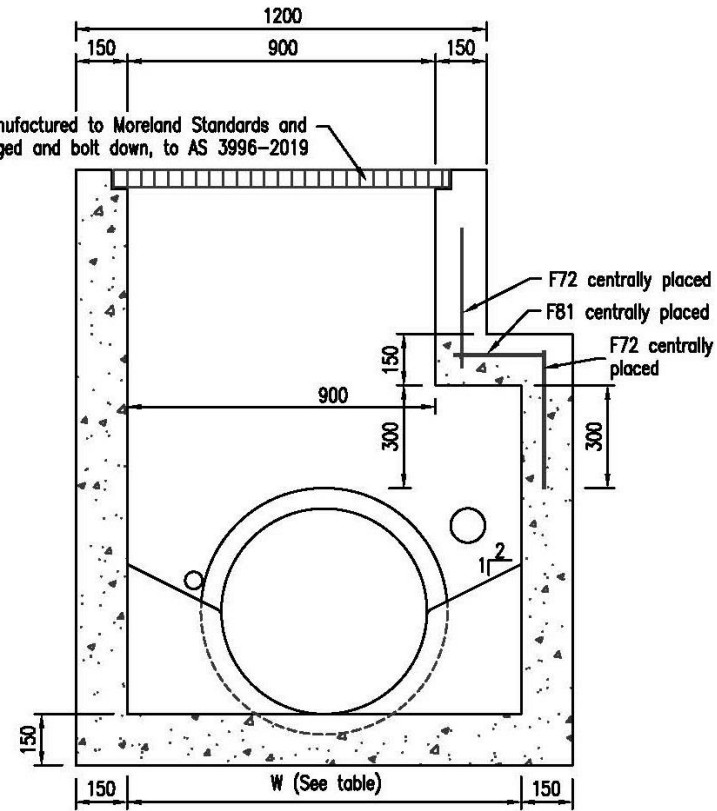

FOR PIPES OVER 750mm  $\phi$   
SECTION A-A

Pipe $\phi$	W
750	1000
825	1100
900	1150
1050	1300

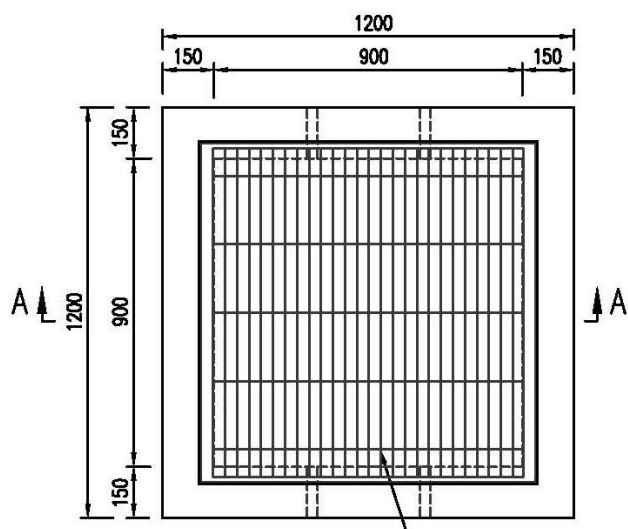

P L A N

Grates to be galvanised and manufactured to Moreland Standards and to be class D, Bicycle Safe, hinged and bolt down, to AS 3996-2019