

Grated Pit (600x900) A140.07



GENERAL

DESIGN STATEMENT

The grated pit is a standard open grate pit located within ROW or paving areas. The grate is selected depending on traffic conditions.

APPLICABLE LOCATION

The grating pit should be used where advised by City Infrastructure Department of Merri-bek City Council.

COUNCIL STANDARD DRAWING

SD 125 Grated pit (600x900mm)

CROSS REFERENCE DOCUMENT

- Merri-bek City Council Standard Specifications: Sections 80 & 60. See Also: Urban Stormwater: Best Practice Environmental Management Guidelines; CSIRO Publishing.

STANDARD SPECIFICATION

Fixing: Hinged and bolt down

Concrete strength: 25 Mpa, unless stated otherwise.

Pits: Shall be cast monolithically. Cement render shall only be used to repair defects. Pits over 2m in depth shall have SL72 reinforcing fabric placed centrally in walls.

Step irons shall be fitted to pits greater than 1m in depth (See SD 190). Minimum internal dimensions to be 600x600mm.

Refer to Notes 1-3 as detailed in general note.

SUPPLIER

Supplier of grates:

- Access Covers P/L
- R&S Grating P/L
- SVC Products P/L
- Terra Firma Industries P/L
- Weldlok Grates P/L
- Gatic P/L or approved similar

MAINTENANCE

Street Cleansing Unit: Cleaning will be undertaken as per current schedule.

GENERAL NOTES

1. For bluestone paver or asphalt right of ways, any exposed concrete shall be charcoal coloured.
2. Grate to be Access Covers P/L
 - R&S Grating P/L
 - SVC Products P/L
 - Terra Firma Industries P/L
 - Weldlok Grates P/L
 - Gatic P/L or approved similar
3. Grates and frame shall be galvanised steel with the grate hinged to its frame. The proposed grate and frame set must be approved by Council and to be bicycle safe prior to being used.

A140.07 Grated Pit (600x900)

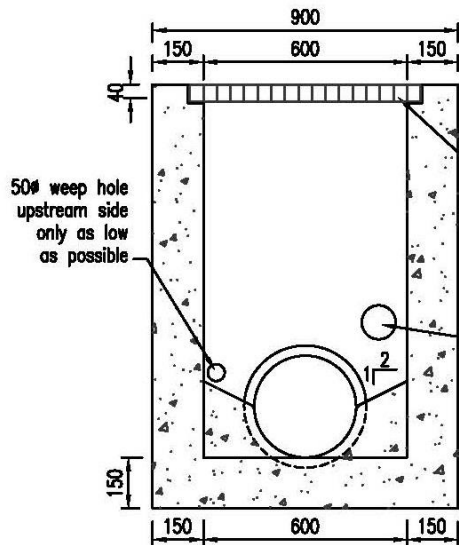

50# weep hole upstream side only as low as possible

Grates to be galvanised and manufactured to Moreland Standards and to be class D, Bicycle Safe, hinged and bolt down, to AS 3996-2019

AG entry as required

Pipe ϕ	W
To 375	600
450	700
525	750
600	850
750	1000

FOR PIPES UP TO 375mm ϕ
SECTION A-A

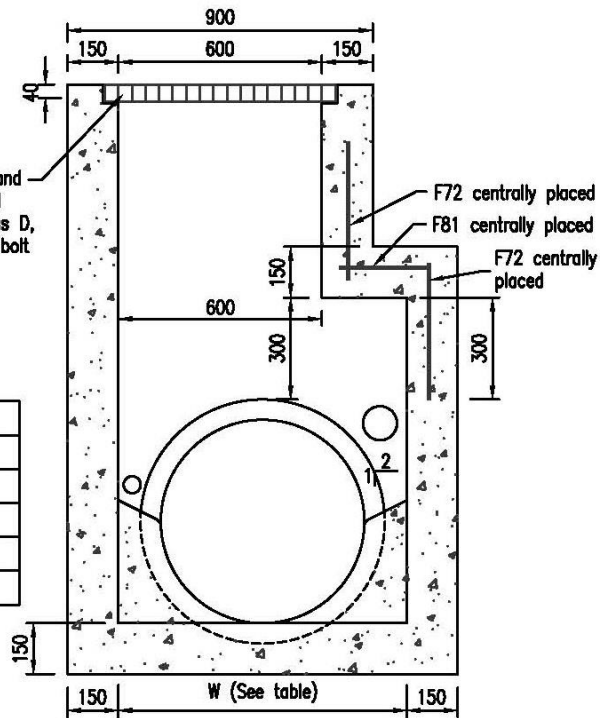

F72 centrally placed
F81 centrally placed
F72 centrally placed

FOR PIPES OVER 375mm ϕ
SECTION A-A

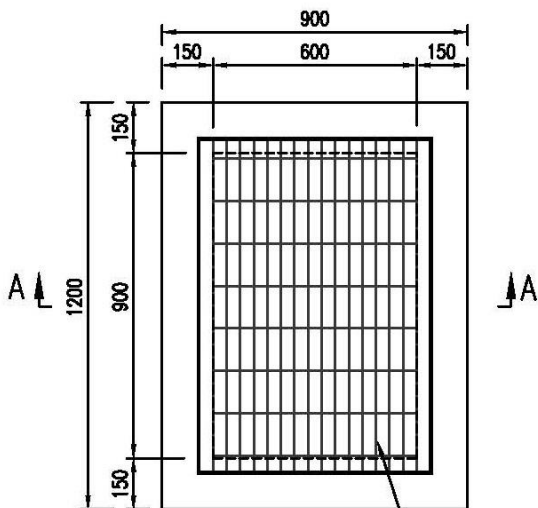

P L A N

Grates to be galvanised and manufactured to Moreland Standards and to be class D, Bicycle Safe, hinged and bolt down, to AS 3996-2019