Grated Pit for Dish Channel A140.06



GENERAL

DESIGN STATEMENT

Grated pit for dish channel is a drainage system component that captures surface run off and discharges the run off into underground drainage pipes.

APPLICABLE LOCATION

Grated pit for dish channel should be located at low points in the dish channel.

COUNCIL STANDARD DRAWING

SD 124 Grated pit for dish channel

CROSS REFERENCE DOCUMENT

- Australian Standard AS 3996-2019 and Merri-bek Standard Specification Section 60 and 80.

STANDARD SPECIFICATION

Refer to Notes 1-6 as detailed in General Note.

SUPPLIER

Supplier of grates:

- Access Covers P/L
- R&S Grating P/L
- SVC Products P/L
- Terra Firma Industries P/L
- Weldlok Grates P/L
- Gatic P/L or approved similar

MAINTENANCE

Road Maintenance Unit: Replace the whole top section of damaged pit to a depth of 300mm minimum.

Street Cleansing Unit: Cleaning will be undertaken as per current schedule. Traffic management may be required.

GENERAL NOTES

1. Concrete strength = 25 Mpa, unless stated otherwise.
2. Pits shall be cast monolithically. Cement render shall only be used to repair defects.
3. Pits over 2m in depth shall have F72 reinforcing fabric placed centrally in walls.
4. Step irons shall be fitted to pits greater than 1m in depth (See SD 190).
5. Minimum internal dimensions to be 900 x 600
6. Grate to be manufactured to Merri-bek Standards and to be Class D, Bicycle Safe, Hinged and Bolt down, to AS 3996-2019 and be galvanised steel V-shaped. Similar grate must be approved by Council before use.

A140.06 Grated Pit for Dish Channel

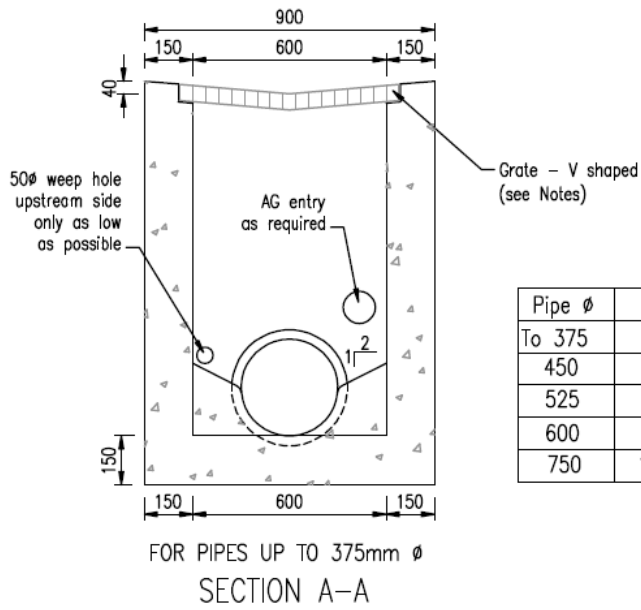

Pipe ϕ	W
To 375	600
450	700
525	750
600	850
750	1000

