

# Side Entry Pit Chute A140.04



## DESIGN STATEMENT

The side entry pit chute is an extension of the inlet of a side entry pit where the pit is not abutting the kerb and channel.

## APPLICABLE LOCATION

The side entry pit chute detail should be used within streetscape improvements (as directed by City Infrastructure Department) in situations where adjustments to kerb alignments are not large enough to warrant the relocation of existing stormwater pits or construction of an extra pit.

## COUNCIL STANDARD DRAWING

SD 116 Side entry pit chute

## CROSS REFERENCE DOCUMENT

- Merri-bek Standard Specifications Section 80 & 60
- Vic Road Specifications: Drainage Specifications: Sections 701, 702, & 60.

## STANDARD SPECIFICATION

**Concrete:** Strength 25 MPa, unless stated otherwise.

**Cover:** Cover shall be Class B Lightweight Composite pit cover compliant to AS 3996-2019.

**Colour:** The colour of the Lightweight Composite pit cover should match adjacent surface (i.e. Green for nature's trips, grey for concrete paving, charcoal for asphalt).

The Merri-bek City Council Logo should also be embossed on the top of the pit lid.

## SUPPLIER

### Supplier of pit covers

- Access Covers Australia P/L
- R&S Grating P/L
- SVC Products P/L
- Terra Firma Industries P/L
- Gatic P/L or approved similar.

**Supplier of lintels:** SVC Products P/L. [www.svc.net.au](http://www.svc.net.au) or similar.

## MAINTENANCE

**Street Cleansing Unit:** Cleaning will be undertaken as per current schedule.

## GENERAL NOTES

1. This standard drawing is to be used in conjunction with standard drawings SD 118 and SD 121.
2. In case of construction of a new pit chute to an existing junction or side entry pit, appropriate opening must be cut out of the existing pit. The chute must be tied to the existing pit with tie bars (12 deformed steel bars, 200mm in length @ 300mm centres, embedded in existing concrete with an epoxy glue). The concrete joining interface must be roughened before casting new concrete.

---

# A140.04 Side Entry Pit Chute

---

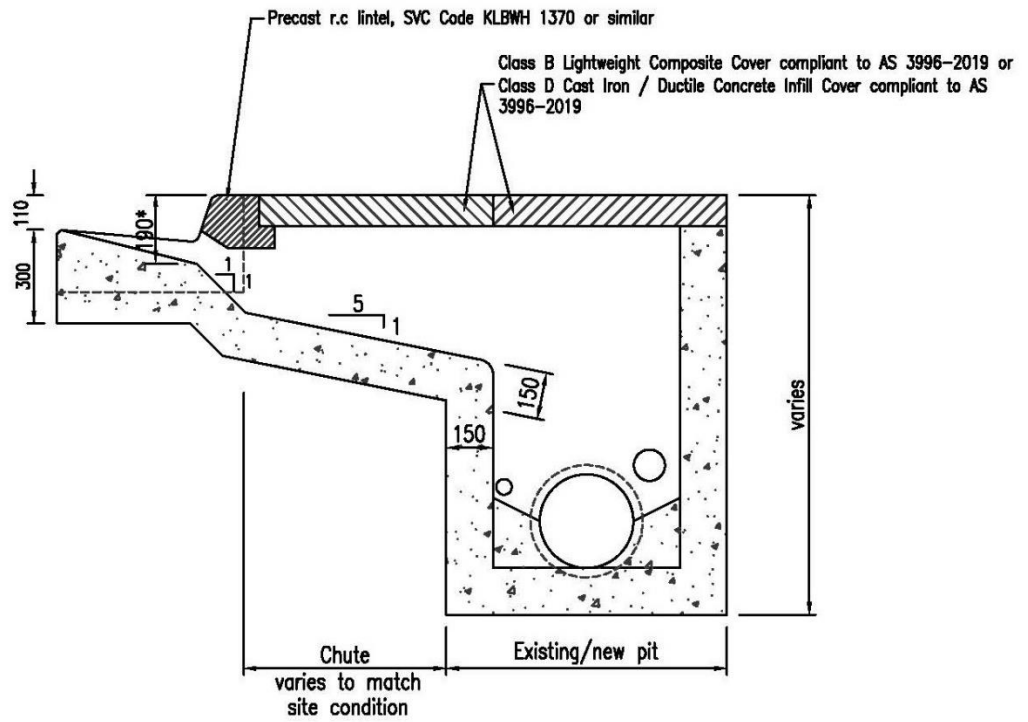

SECTION