

Concrete Shared Bicycle Path A110.03



GENERAL

GENERAL NOTES

1. "T" = 100mm with SL62 reinforcement fabric placed at 30mm cover. "T" = 125mm with SL72 reinforcement fabric placed at 30mm cover, where shared path abuts kerb and/or kerb & channel, or across maintenance vehicle tracks.
2. Provide contraction joints at 1.5m intervals and expansion joints at 15m intervals. The joints to be at right angles to the direction of the shared path unless specified otherwise and to be in accordance with SD291 and Technotes 200.02. Expansion joints shall not have dowels.
3. Where an existing section of shared path is to be reinstated, the section to be replaced shall be between existing joints.
4. Coloured concrete, where specified, shall be by adding "Abilox"- 'River Blend Beige' colour powder or equivalent into the premix concrete. The rate of powder by weight of cementitious binder (approx. 25kg per cubic metre of concrete). Coloured topping required in parks, with a non-skid painted centre-line in high use areas.
5. Concrete shall be ready mix in accordance with relevant Australian Standards and shall have a 28 day compressive strength of 25 MPa minimum.
6. All concrete shared paths should be a minimum of 2400mm wide with a rough broom finish.
7. Saw or wet formed contraction joints should be at 1500mm centres. Expansion joints should be provided at 15 metre centres.
8. The pathway should stand 100mm proud of edges to make them safe for cyclists. Shared concrete footpaths should be constructed to meet with pedestrian crossovers.

DESIGN STATEMENT

The standard concrete shared path is a smooth continuous surface designed to enable greater ease of walking and riding comfort, especially for elderly and disabled pedestrians. The shared footpath is designed for cyclists and pedestrian use.

APPLICABLE LOCATION

The concrete shared path should be used in all new shared footpath construction within the municipality, in creek corridor areas, parklands and other designated areas, especially to create connections to other bicycle routes.

COUNCIL STANDARD DRAWING

SD 222 Concrete shared path

CROSS REFERENCE DOCUMENT

- AS 1428.1 – 1998 (Australia Specification & Standard Design for Access & Mobility). AS 1379 (Australia Specification & Standard supply of concrete).
- See Merri-bek Specifications: Sections 61, 80 & 82 and Section 23 Nature Strip. See also Vic Roads Concrete Specifications: Part 2, Section 180 Ride quality for Pavements. Section 501 Concrete Base and Sub-base Pavement courses, Section 820 Recycled & Crushed Concrete for Pavement and Sub-base & light duty base. See also Planning and Design Guidelines for Bicycle Facilities (Ministry of Transport).

STANDARD SPECIFICATION

See General Notes.

SUPPLIER

N/A

MAINTENANCE

Road Maintenance Unit: Replace sections of shared concrete path between nearest joints, do not patch small areas.

Street Cleansing Unit: Cleaning will be undertaken as per current schedule and immediately after floodwaters recede in creek areas. Edges of shared concrete path should not be sprayed with herbicide as it leads to erosion.

Open Space Maintenance Unit: All general path maintenance such as the removal of leaf litter and debris after Creek level has subsided.

A110.03 Concrete Shared Bicycle Path

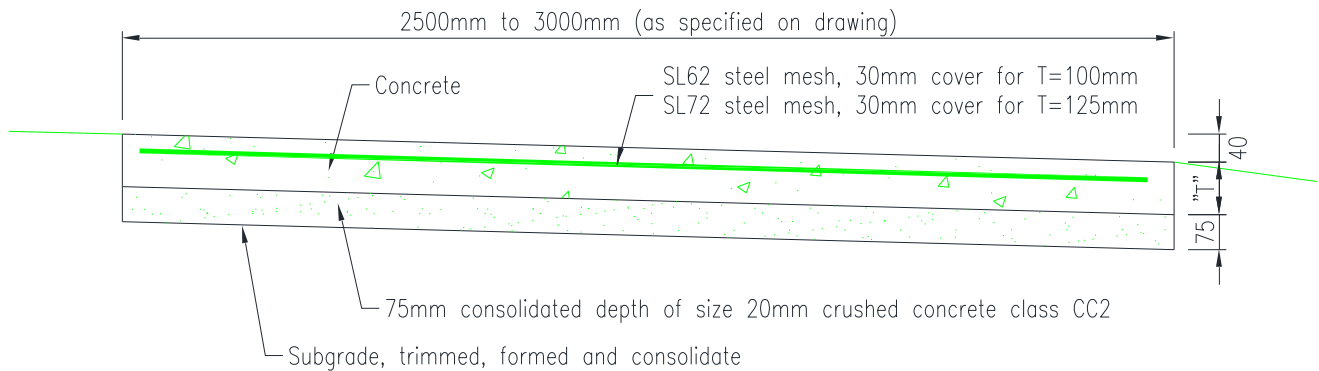

CROSS SECTION
SHARED CONCRETE PATH

NOTES:

1. "T" = 100 mm with SL62 reinforcement fabric placed at 30mm cover
"T" = 125 mm with SL72 reinforcement fabric placed at 30 mm cover, where shared path abuts kerb and/or kerb & channel, or across maintenance vehicle tracks
2. Contraction sawn joints at 1.5m intervals must be cut within 24 hours after placing concrete, and expansion joints at 15m intervals. The joints to be at right angles to the direction of the shared path unless specified otherwise and to be in accordance with Technotes A200.02. Expansion joints to be Connolly Expansion Joint or approved alternative.
3. Where an existing section of shared path is to be reinstated, the section to be replaced shall be between existing joints
4. Coloured concrete, where specified, shall be by adding "Abilox" colour powder or equivalent into the premix concrete. The rate of powder is 8.3% by weight of cementitious binder (approx. 25kg per cubic metre of concrete)