

# Better Quality Design Checklist

## Two Dwellings on a lot



**Merri-bek**  
City Council

To qualify under this stream:

- A pre-application meeting with Council must be undertaken;
- A pre- ESD certification from Council's ESD Unit must be obtained; and
- Your development must meet:
  - ☑ Mandatory requirements of the zone
  - ☑ Clause 55 standards
  - ☑ Accessibility requirements
  - ☑ Design requirements and Neighbourhood Character requirements (Clause 55.01)
  - ☑ ESD Certification.
  - ☑ All information requirements.

All dimensions of the listed requirements must be clearly shown on the plans submitted with the application and detailed in the response below.

### Reports and written submissions

- ESD Certification and supporting documents
- Table 1: Mandatory Requirements of the zone
- Table 2: Accessibility Requirements
- Table 3: Design Requirements
- Table 4: Clause 55 Requirements

# INFORMATION REQUIREMENTS Checklist



Merri-bek  
City Council

## Title

A full copy of Title (no older than 3 months) including the Registered Search Statement, Plan of Subdivision and a full copy of any covenant that is registered on Title, which is available at: <https://www.landata.vic.gov.au/>

## If the building impacts on a tree on an adjoining property:

An **Arborist Report** prepared by a suitably qualified Arborist which assesses the vegetation on-site and within 5 metres of neighbouring properties as detailed in the Australian Standard AS4970-2009 Protection of Trees on Development Sites, including a calculation of any encroachment into Tree Protection Zones. The arborist report must make specific recommendations in relation to any proposed buildings and works located within identified Tree Protection Zones, to ensure their ongoing health and stability. A guide to requirements of an Arborist Report is available here: <https://www.Merri-bek.vic.gov.au/globalassets/areas/open-space/Merri-bek-arborist-report-guide.doc>

## If the site is within 300 metres of a noise source (railways, freeways, tollways, busy roads or industry)

An Acoustic Report prepared by a suitably qualified Acoustic Engineer which demonstrates that dwellings have been designed and constructed to include acoustic attenuation measures to reduce noise levels from off-site noise sources.

## Reports

A **planning report** to satisfy the requirements of Standard B2 (Residential Policy) of the Merri-Bek Planning Scheme.

## Plans

A **survey plan**, showing the title boundaries and the location of existing boundary fencing.

A **garden area plan** showing clearly how the garden area has been calculated.

A **Neighbourhood and Site Description plan (to scale)** and a **Design Response Plan** clearly showing the development in the context of at least 4 lots on either side of the subject site, opposite the site and behind the site. (This can not be aerial imagery).

**Floor plans (to scale):**

Title boundaries shown on every floor plan.

Finished floor levels to Australian Height Datum (AHD) or a Relative Level (RL) with the fixed datum point clearly indicated on the plan.

Ground areas to be noted as hard surfaces or permeable.

Dimensions of the canopy tree planting areas to comply with Standard B13 of the Merri-bek planning scheme.

Location of buildings, private open space and habitable room windows on adjoining properties.

Location of solar panels on adjoining properties.

Location of mature trees existing on the site or within 5 metres of the property boundary. Mature trees are greater than 8 metres in height and have a trunk diameter greater than 40 centimetres (measured 1.2 metres

from the ground).

Location of any council street trees and the distance of the proposed crossover to the canopy and trunk of the street tree

Street frontage features such as poles, street trees and kerb crossovers.

Setbacks to windows on adjoining properties dimensioned

The location of solar panels (i.e. photovoltaic or hot water, as required) as proposed within the accompanying Sustainable Design Assessment/Sustainability Management Plan.

The location of shading devices to any north, east and west habitable windows as proposed in the accompanying Sustainable Design Assessment/Sustainability Management Plan (if applicable).

Location of easements

Location of proposed letterboxes, bins, electricity, water and gas meters

Location of air conditioning units and building services

Vehicle crossing with 1 metre straight splays on both sides commencing where the footpath meets the nature strip and finishing at the kerb in accordance with Council's Standard Vehicle Crossing design.

**Elevation Plans (to scale):**

The slope of the land, indicating the differences between natural ground levels compared to proposed floor levels. The elevation plans need to show finished floor levels and the overall building height to Australian Height Datum (AHD) or a Relative Level (RL) that will not be affected during construction.

Indicative setback lines required by Standard B17 (Side and rear setbacks)

Wall heights dimensioned above natural ground level.

Materials and finishes including swatches

Internal elevations

Shading devices to the north, east and west habitable windows as proposed in the accompanying Sustainable Design Assessment/Sustainability Management Plan, including a detailed diagram of the proposed type of shading device.'

Streetscape elevation clearly showing the proposed development in the context of at least both buildings either side of the development

Overall building height above natural ground level

Details of any proposed front fence, including scaled elevation plans (if a front fence is proposed)

**Shadow diagrams** to scale (preferably 1:100) at 9am, 10am, 11am, 12pm, 1pm, 2pm and 3pm on 22 September showing the following:

The area and percentage of existing overshadowing cast on the secluded private open space of adjoining properties by existing dwellings, outbuildings and fences on the site and adjoining lots.

The area and percentage of proposed overshadowing cast on the secluded private open space of adjoining properties by the proposed development in a manner that differentiates it from the existing shadowing (e.g. defined using different hatching, colours or shading)

The entire property boundaries of the adjoining properties and the entire location of secluded private open spaces.

**A Landscape Plan** showing:

Location of mature trees existing on the site or within 5 metres of the property boundary. Mature trees are greater

than 8 metres in height and have a trunk diameter greater than 40 centimetres (measured 1.2 metres from the ground).

Existing vegetation including any proposed tree removal;

Proposed landscaping works and planting that includes information on vegetation selection, quantities, location, establishment and maintenance with the requirements of Clause 3.0 of the Schedule to the Neighbourhood Residential Zone and the Merri-bek Tree Planting Manual for Residential Zones, 2014.

# ASSESSMENT Checklist



**Merri-bek**  
City Council

**TABLE 1: MANDATORY REQUIREMENTS OF THE ZONE**

	Select all that apply:	Shown on plans no. (Reference drawing number)
<b>Building Height</b>	<input type="checkbox"/> NRZ: 9 metres / 2 storeys <input type="checkbox"/> GRZ: 11 metres / 3 storeys	Click or tap here to enter text.
<b>Garden Area</b>	<input type="checkbox"/> <400 square metres <input type="checkbox"/> 400 – 500: 25% <input type="checkbox"/> 500 – 650: 30% <input type="checkbox"/> 650+: 35%	Click or tap here to enter text.

**TABLE 2: ACCESSIBILITY REQUIREMENTS**

**Entry and bedroom**

- One bedroom or adaptable space provided at ground floor level which is at least 10 metres in area and has an external window.
- Accessible path from the street and car park areas to a level entry.

**Bathroom**

- An accessible bathroom including a toilet and shower provided at ground floor level which includes the following:
  - Bathroom entrance of 850mm wide
  - Hobless (step/less) shower
  - Accessible layout with circulation area provided

**Example: Compliant, accessible bathroom layout**

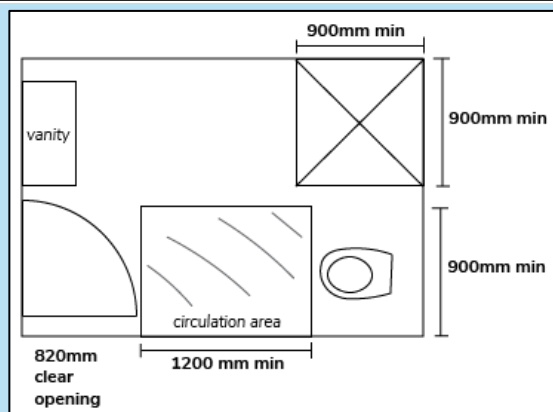

## TABLE 3: DESIGN REQUIREMENTS

### Quality design

- Contemporary design details (see Design Exemplars for examples).
- No narrow/opaque windows facing the street
- Bins and services are concealed and located for convenient access by residents
- No blank facades
- No unreasonable overshadowing of solar panels on adjoining lots
- Screening must be:
  - Necessary (only windows which require screening under Standard B22 to be screened);
  - No film on glass; and
  - Considered (Where a planter box or angled fin can be used to meet B22, this should occur)

### Tandem development (front and back):

- Communal service area to be less than 1.5 metres in height (for example, mailboxes, meterboxes etc) and conveniently located
- Garage dominance reduced through:
  - A materials that integrates with the overall façade design; and
  - Set back 1 metre behind the front façade or located under a porch/ pergola structure.

### Quality materials

- Highly durable, low maintenance materials provided
- Plain concrete paving be limited to vehicle crossing and parking areas
- No synthetic turf

### Examples

**Quality design:** *contemporary design, considered screening, concealed services*

**Quality materials:** *High quality materials (brick, timber, metal cladding – no render),*



## Minimised bulk

Dwelling is broken up into at least 2 distinct elements (using extruded frame, recess, cantilever, variation in materials)

1 metre setback from one side boundary for the depth of at least one room/garage

Tandem development (front and back):

Break is provided between front and rear dwelling at first floor level

Side by side developments:

Individual roof forms for each dwelling (rather than two dwellings under one roof; dwellings can have roofs forms that are the same)

## Landscaping

No removal of mature trees on site

No removal of street trees

No encroachment of more than 10% into the TPZ of any mature tree on an adjoining property

## Integration with the street

Front dwelling/s orientated to face the street

Entrances to dwellings clearly visible, identifiable from street and internal accessways

Garages are less than 50% of the frontage

Garages to be either one metre behind the façade or integrated into the frontage through a porch/pergola

Porch and usable entry space provided

Front fences to be less than 1.5 metres (or 2 metres if facing a road in a Transport 2 Zone).

Habitable rooms facing the street (ground floor)

## Open Space

N/A; or

Dwelling interacts with public open space

## Examples

**Minimised bulk:** Break at first floor level, depth is created by breaking up dwellings into distinct elements

**Landscaping:** Mature tree retained in front setback

**Integration with street:** Ground floor habitable windows, clear orientation to street



## Car Parking and access

- Meets the requirements of Clause 52.06 – Car Parking and does not seek a reduction in car parking.
- Car parking located close and have convenient access to dwellings
- Accessways are less than 40% of the frontage
- No more than one accessway is provided per dwelling
- Accessways are 3 metres in width with 1 metre splays
- Outdoor lighting to any shared driveway
- Two vehicle crossings at least 8 metres apart as measured along the property boundary.

Where access is from a rear laneway:

- Swept paths / turning circles are provided showing a B85 vehicle can access the car spaces.

### Example:

*Separated vehicle crossings, active frontages, no dominant car parking structures*





## TABLE 4 – CLAUSE 55 (TWO DWELLINGS ON A LOT)

### B6 - Street setback

Select one:

- 9 metres; or
- The average of the neighbouring properties;

Corner lots

- Equal to the setback of the adjoining lot fronting the street; and
- A front setback facing a side street to be at least 3 metres.
- A side setback equal to the adjoining property or 2 metres, whichever is the lesser.

Setback: [Click or tap here to enter text.](#)

Plan: [Click or tap here to enter text.](#)

### B8 - Site Coverage

- Coverage is 60% or less

Coverage: [Click or tap here to enter text.](#)

Plan: [Click or tap here to enter text.](#)

### B9 - Permeability

- Permeability is 20% or more

Permeability: [Click or tap here to enter text.](#)

Plan: [Click or tap here to enter text.](#)

### B13 – Landscaping

- Planting along vehicle accessway
- Front setback area provided for both dwellings
- Rear setback area provided for both dwellings
- Compliant trees (height and canopy) both dwellings

Dwelling 1    Dwelling 2

#### Front setback

Area (l X w):

Tree height at maturity:

Canopy width at maturity:

#### Rear setback

Area (l X w):

Tree height at maturity:

Canopy width at maturity:

#### Front setback under 4.5 metres:

- Area over 10sqm
- Tree height: 6 – 8m at maturity
- Canopy: 5 metres at maturity
- Minimum dimension 4.5 metres wide

#### Front setback over 4.5 metres

- Area at least 4.5 by 4.5
- Tree height: 8-15 metres at maturity
- Canopy: 7 metres at maturity

#### Rear setback:

- Area at least 4.5 by 4.5
- Tree height: 6 – 8m at maturity
- Canopy: 5 metres at maturity

### **B15 – Parking location**

Complies with objective. Convenient parking provided and vehicular noise is limited as the application is for a two dwelling development.

### **B17 - Side And Rear Setbacks**

Complies with Standard

Wall height: [Click or tap here to enter text.](#)

Setback: [Click or tap here to enter text.](#)

Plan: [Click or tap here to enter text.](#)

### **B18 - Walls On Boundaries**

No wall on boundary; or

Maximum height is less than 3.6; and

Average height is less than 3.2

Meets the length of the wall on the boundary standard (meets formula)

### **B19 - Daylight To Existing Windows**

3 square metres, minimum dimension 1 sqm clear to the sky; and

Walls or carports more than 3 metres in height opposite existing habitable room window should be set back 50% of the wall height, for a 55 degree arc;

### **B20 - North Facing Windows**

Not applicable; or

Meets standard (meets formula)

Wall height: [Click or tap here to enter text.](#)

Setback: [Click or tap here to enter text.](#)

Plan: [Click or tap here to enter text.](#)

### **B21 - Overshadowing Open Space**

75% or 40 square metres of the secluded private open space (the lesser area) unshaded for at least 5 hours

Minimum dimension of 3 metres provided

Or

No additional overshadowing at any time (including pre-9am and post 3pm)

### **B22 - Overlooking**

Windows have permanent, fixed screening to a height of 1.7 metres above floor level. Screening to be no more than 25 per cent transparent .

Windows not within 9 metre arc of SPOS

Windows are offset 1.5 metres from other windows

### **B23 - Internal Views**

No more than 50% of the private open space dwelling in the same development to be overlooked.

### **B24 - Noise Impacts**

Select one:

Site is not within 300 metres of any noise sources (railways, busy roads or industry)

or

Site is within 500 metres of a noise source and an Acoustic Report prepared by a suitably qualified Acoustic Engineer which demonstrates that dwellings have been designed and constructed to include acoustic attenuation measures to reduce noise levels from off-site noise sources has been provided.

### **B27 - Daylight To New Windows**

A new window must abut:

- A light court of 3 square metres in area with a minimum dimension 1 sqm clear to the sky or
- A verandah provided it is open for at least one third of its perimeter, or
- A carport provided it has two or more open sides and is open for at least one third of its perimeter
- Variation required for the purpose of compliance with ESD policy around window shades.

### **B28 - Private Open Space**

- 40 square metres total
- 25 square metres secluded
- Minimum width of 3 metres
- Convenient access from a living room

Plan: [Click or tap here to enter text.](#)

### **B29 - Solar Access To Open Space**

Select one:

- Open space is to the north of the lot; or
- Setback complies with the standard (meets formula)

Setback: [Click or tap here to enter text.](#)

Plan: [Click or tap here to enter text.](#)

### **B30 - Storage**

6m<sup>3</sup> of externally accessible, secure storage space provided.

Plan: [Click or tap here to enter text.](#)